

DRAKE INDUSTRIES

79 FILLMORE AVE, TONAWANDA, NY 14150
 PHONE: 716-880-0957 FAX: 716-408-8876

PORTABLE ENVIRONMENTAL CONTROL UNITS FOR ALL APPLICATIONS

Model- DI-2.0HHP ECU

Dimensions are Inches
 Weight 270 pounds

PERFORMANCE

COOLING CAPACITY	24,000 BTU/HR
RETURN AIR CONDITION DB	20 DEG DROP FROM AMBIENT
CONDITION AIR SUPPLY	750CFM MIN. @ 0.1 WET COIL ON HIGH
HEATING CAPACITY	24,000 BTU/HR HEAT PUMP PLUS 17732 TOTAL 41732 BTU'S
DEHUMIDIFYING	50% RH MAX
MAX OPERATING AMBIENT	125 DEG F / 52 DEG C
RATING AMBIENT	95 DEG F / 35 DEG C
MIN OPERATING (HEATING)	-20 DEG F

MECHANICAL

REFRIGERATION STAGES	1 STAGE
COMPRESSOR TYPE	1 SCROLL
REFRIGERATION TYPE	R-410
EVAPORATOR COIL MATERIAL	COPPER TUBE / ALUM FIN
CONDENSER COIL MATERIAL	COPPER TUBE / ALUM FIN
EXPANSION VALVE TYPE	BI DIRECTIONAL EXPANSION TUBE
CIRCULATING FAN	FORWARD CURVE
CONDENSER FAN TYPE	PROPELLER
FRAME AND PANEL MATERIAL	GALVANIZED STEEL
FINISH	DESERT TAN
WEIGHT	270 APX LBS

DUCTS

DUCT DIAMETER	12"
NUMBER OF SUPPLY DUCTS	1
NUMBER OF RETURN DUCTS	1
EXTERNAL STATIC PRESSURE	1.0"

ELECTRICAL

VOLTAGE/PHASE/HZ	230/115v SINGLE PHASE 60HZ (24 VAC CONTROLS)
POWER DRAW COOLING	RLA 11.1, 2.5KW LRA 57
POWER DRAW HEATING Res heat	RLA 33.2, 5.2KW LRA 57 Heatpump and Resistance heat combined
CONNECTOR TYPE / MODEL	YOUR CHOICE
MOTOR PROTECTION	BREAKER & CONTACTORS
COMPRESSOR PROTECTION	INTERNAL THERMAL PROTECTION & MOTOR CONTACTOR
HEATING STAGES	2 STAGE HEAT PUMP PLUS RESISTANCE HEAT
COOLING CONTROLS	THERMOSTAT - ROOM AIR SENSING
HEATING CONTROLS	THERMOSTAT - ROOM AIR SENSING
MODE SELECTOR SWITCH	ON-OFF AUTOMATIC TEMPERATURE FAN ALWAYS ON
COOLING SAFETY SWITCHES	STD - HI & LO PRESSURE SWITCHES AND HI PRESSURE RELIEF
HEATING SAFETY SWITCHES	HI TEMPERATURE CUT-OUT (BI METAL DISK TYPE)

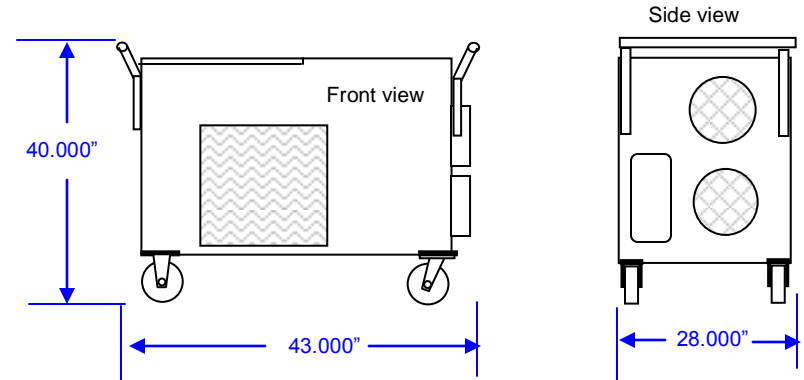

FEATURES

ON BOARD STORAGE	YES
DEHUMIDIFICATION	NO
HUMIDIFICATION	NO
PHASE PROTECTION	NO
REMOTE CONTROL	YES
EMI SUPPRESSION	NO
EXTERNAL SERVICE PORTS	NO
STAGGERED START	NO
FILTER WARNING LIGHT	NO
ELAPSED TIME INDICATOR	NO
EXPLOSION PROOFING	NO
MAIN POWER DISCONNECT	YES
MOTORIZED FRESH AIR DAMPER	NO

MOBILITY

FORK POCKETS	NO
SOFT RIDE CASTERS	YES
LIFT HANDLE	YES
BREAKING SYSTEM	YES